



ASPE Pipeline News

Northern California Chapter

The American Society of Plumbing Engineers
Chapters May Not Speak for the Society



MEETING NOTICE

Meeting Notice

Date: Tuesday,
November 13, 2007

Place: Old Spaghetti Factory
at Hazel & Folsom Blvd.
Rancho Cordova, CA

Time: 11:45 a.m.—1:00 p.m.

Meal: Lunch (\$15.00)

Topic: Discuss changes to
Food Facilities code and the differ-
ent things that they control within
the food service facilities (Water
heater sizing for example)

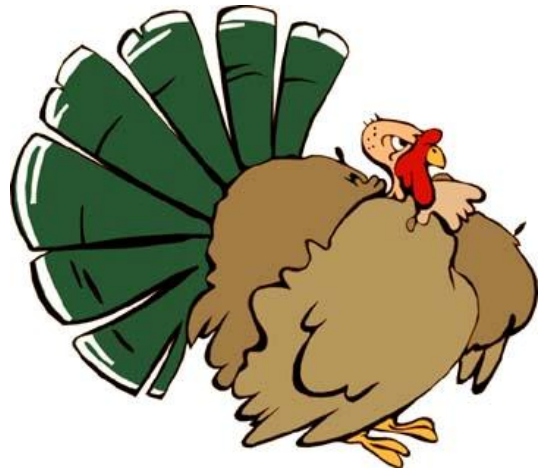

THIS MONTH: November we are having our annual food drive for the local food bank. Bring any and all nonperishable foods to this months meeting. Thank You for your Support.

Featured Speaker:

Colleen Maitoza
with Sacramento County Environmental
Management Department.

Win a Free Lunch at Next Membership Meeting, See VPM Report

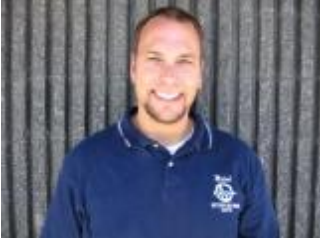

President's Message

Hello and welcome!

The holiday season is now in sight and fast approaching. Crazy! It seems like only yesterday that we were enjoying our summer vacation and now we're looking at celebrating Thanksgiving! Where has the time gone?

Maybe it's not so much that time has flown by, but rather we're all so deeply embroiled in work that we've not had the time to take it all in?!?

Anyway.....

Many thank to our speaker this last month from AB&I Foundry, and my sincere apologies for not making the meeting. From what I've heard from the other Board Members it was a very well attended and informative session.

Speaking of attendance and meeting places, it was a thought of the Board that we'd shake things up each month and flip back and forth between the two Spaghetti Factories in mid-town and at Hazel Avenue. Unfortunately, it seems to have added a level of confusion and so we've decided to base all of our meeting with the exception of November, December & January at the Spaghetti Factory in mid-town. Consistency breeds familiarity and comfort. Therefore all our meeting will now be held in mid-town with the exception of the three months noted.

We wish our Administrative Secretary – Joseph Nicolich well as he departs for Atlanta for the ASPE Technical Symposium. There is a full slate of technical programs in which Joseph will be attending. As well he's been dispatched with orders to bring back any and all technical program handouts he can get his hands on. Look for copies to be made available to all members at future Membership Meetings.

On a final note, with the holiday season comes our annual fund raising efforts for the needy. This month being Thanksgiving, we'll be collecting non-perishable food items coupled with items purchased with chapter funds that'll then be donated to the Sacramento Food Bank. We ask that you PLEASE scour your kitchen cupboards and give what you can. Let's help those that are less fortunate and in doing so make it a joyous and happy holiday for everyone.

Michael Rodgers
President-Nor Cal Chapter of ASPE



V.P. Technical Message

Hello everyone!

I would like to thank all of you for coming to our October meeting, which included presentation from Gregg Carr from AB&I discussing the important changes to the standards of the ASTM and CISPI and how it relates to the UPC. Also, a big thanks to Gregg Carr for providing this very informative presentation.

This month's meeting will be a discussion about how to correctly design a food facility, presented by Colleen Maitoza with Sacramento County Environmental Management Department.

Colleen's presentation will include how to correctly size the water service and water heaters. She will also include the changes that have been made to the current code and what her department looks for in submitted drawings.

This presentation will be very informative and you will not want to miss it! Also, please note that at this meeting we will be collecting canned food or non-perishable food for the Sacramento Food Bank.

I hope to see you all there.

Thank you,

Angela Bowman

VP Technical – Nor Cal Chapter of ASPE

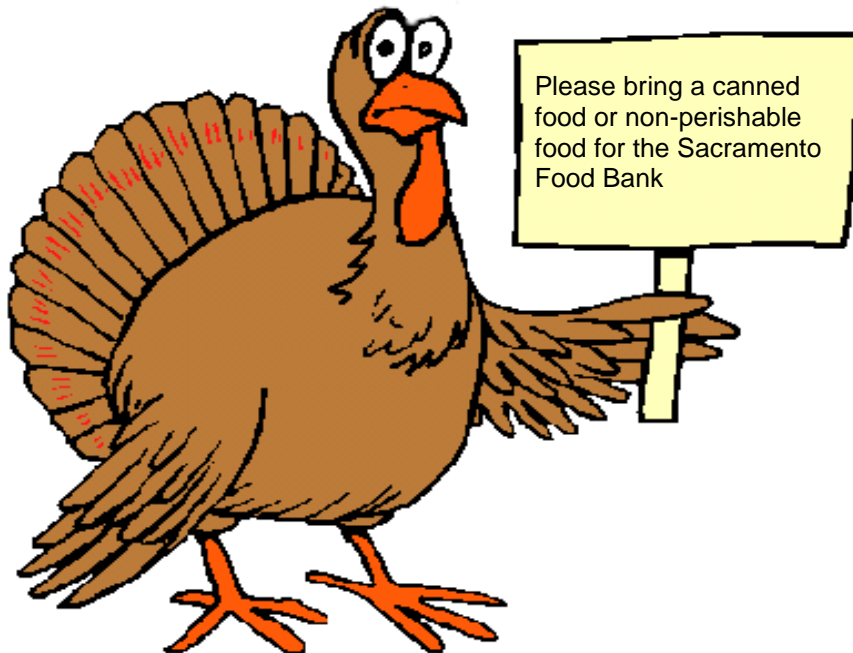



MANUFACTURER'S REPRESENTATIVE
OF THE FOLLOWING PLUMBING PRODUCTS:
CONTACT: BILL KAPANEN 916-632-4780

ITT Bell & Gossett: centrifugal pumps, pressure booster pumping packages, sump pumps

Cemline: Indirect Fired Water heaters for steam to water or hot water to water applications

Danfoss Flomatic: Backflow Preventers, Automatic Control Valves, Check & Foot Valves

FlowTherm Systems: Preassembled UL Listed Skids for pressure boosting, and domestic water heating

Laars Heating Systems: High Efficient Hot Water Boilers, and hot water storage tanks

Patterson Kelley (PK): High Efficient Hot Water Boilers

Weil Pump: Submersible and Column type pumps for sewage & dewatering applications



V.P. Legislative Message

On October 11, 2007 the governor of California signed legislation mandating ultra low flush water closets and urinals by the year 2014. The legislation was written with no consideration of the functional performance of the sanitary sewer system. Reducing the amount of water in the sanitary sewer system will potentially cause system blockages. The ineptness of our State legislature and governor amazes me as they seem to write laws just for the sake of doing so or for personal accolade without regard for technological issues. A good example is the law written by the Legislature prohibiting teenagers, but not all drivers, from using their cell phones while driving for “safety reasons”. Not to long after, a Legislator caused a traffic accident damaging State property and injuring other people, due to reckless driving while talking on a cell phone.

Assembly Bill AB-715 requires that starting January 1, 2014, all water closets and all urinals, other than blow-out urinals, sold or installed in this state shall be high-efficiency water closets and urinals. The date will remain operative unless the California Building Standards Commission includes similar standards in the California Building Standards Code sooner than 2014. A “high-efficiency” water closet is a water closet with a flush volume that does not exceed 1.28 gallons and a “high-efficiency” urinal is one that uses no more than 0.5 gallons per flush. The bill requires manufacturers selling water closets or urinals in this state to offer high efficiency models for sale in a specified percentage of all models offered, including 50% by January 1, 2010, 67% by January 1, 2011, 75% by January 1, 2012, 85% by January 1, 2013, and 100% by January 1, 2014. It would require these manufacturers, by January 30 of 2010, 2011, 2012, and 2013, to inform, the California Energy Commission of the percentage of high-efficiency models it is offering for sale that year. The bill also requires by July 1, 2009, that State agencies adopting or proposing building standards for plumbing systems develop a code that would govern the use of non-water-supplied urinals. There is language in the code that would still allow the use of 1.6 gallon water closets, if it is an “institutional” fixture or if it has dual flush capability and the average volume of two reduced flushes and one full flush does not exceed 1.28 gallons.

In 1992 ASPE’s Research Foundation published a report on the performance of low flow water closets when State and Federal laws required water closets to use only 1.6 GPF in lieu of the 3.5 GPF, which was standard at the time. The Research foundation contracted with the Building Technology Laboratory at The Stevens Institute of Technology to do the laboratory and field testing. The findings in the report for Drain Line Carry testing noted that the combined transfer and transport performance of 1.6 GPF water closets was significantly less in long horizontal drains. A potential for blockage exists for 1.6 GPF water closets in drains 150 feet long at a one percent slope. The report recommended that; 1. The practical significance of the reduced transport efficiency of 1.6 GPF units needed further evaluation. 2. The significance of alternative pipe diameter needs to be researched. 3. New rules for sizing drainage piping with water efficient plumbing fixtures must be developed. 4. More research is needed in the modeling of the movements of waste in drains.

Now fifteen years later politicians are mandating (with no engineering basis) further reductions in the water used in plumbing fixtures. In addition to AB-715 there were three other bills put before the governor related to the building industry. All three pertained to “Sustainable Building Design” and would require State buildings, commercial, and residential construction to incorporate into their construction some of the standards described in the US Green Building Council LEED. The governor vetoed those bills stating in his veto message that “Building standards should not be statutory; the California Building Standards Commission was created to ensure an open public adoption process allowing experts to develop standards and periodic updates to the building codes.” Why the governor didn’t apply that reasoning to AB-715 is anyone’s guess.

Yes, water usage is becoming more and more critical in this State as the population increases by one half million people each year. And yes, we need to incorporate “Green Building” standards into the buildings we design and construct. But like the governor said, building standards need to be left up to the experts to develop.

Thank you and we look forward to seeing you at the membership meeting.

Jim Powell, CPD
VP Legislative - Nor Cal Chapter of ASPE

Lubrizol CPVC Piping Systems.

High quality protection without high metal pricing.

Lubrizol (formerly Noveon, Inc.) offers a family of superior quality CPVC plumbing and fire sprinkler systems for use in high-rise applications, apartment buildings, hotels/motels, commercial installations as well as single and multi-family housing.

FlowGuard Gold® and **Corzan**® water distribution systems and **BlazeMaster**® fire sprinkler systems for commercial and residential applications.

Lubrizol high-performance CPVC product advantages:

- Over 49 years of proven performance
- Substantial installed cost savings
- Ease of installation for flexibility with other trades
- Lightweight for easy handling
- Quality Assurance Program
- Solvent welding for consistent reliable joints
- Will never pit, scale or corrode

For more information contact Harry Moos, Piping Systems Consultant at 916-952-7238, or call our Marketing Department at 888-234-2436. Visit our web sites at: www.flowguardgold.com and www.blazemaster.com

Three names you can trust for all your commercial and residential piping system challenges.

FLOWGUARD GOLD
PIPE & FITTINGS
NOT A DROP OF DOUBT.

BlazeMaster
FIRE SPRINKLER SYSTEMS

CORZAN
PIPE & FITTINGS

Lubrizol

FlowGuard Gold®, BlazeMaster® and Corzan® are registered trademarks of The Lubrizol Corporation
© Copyright 2007 The Lubrizol Corporation



2007-2008 Chapter Calendar of Events

(program topics subject to change)

September—2007	Code Changes & What OSHPD is looking for in their review.
October—2007	Cast iron specifications/standards for UPC for ASTM and CISPI.
November—2007	Discuss changes to Food Facilities code and the different things that they control within the food service facilities (Water heater sizing for example)
December—2007	Discuss pitfalls and tips for a successful plan review
January—2008	Tour of Glumac's Office. Tour to show what they did to try and achieve a LEED Platinum rating
February 2008	"FOG (Fats, Oils, and Grease) Disposal Systems - Learn about the new CPC criteria for sizing, applications, and installation of FOG disposal systems."
March 2008	IAPMO " An Analysis of the California Plumbing Code Changes from 2001 to 2007 Editions" "Siphonic Roof Drainage Design and Review of the New ASPE Standard 45
April 2008	"NFPA 99 Health Care Facilities - The changes in Medical Gas and Vacuum System Requirements from 2002 to 2005 Editions"
May 2008	"Gas System Design using Corrugated Stainless Steel Piping"
June—2008	SUMMER BREAK
July—2008	SUMMER BREAK
August—2008	SUMMER BREAK



Board Meeting Minutes

October 2007 – ASPE Board Meeting Agenda

Date of Meeting: Tuesday, October 16, 2007 @ **Strings (65th & Folsom Blvd.)**
from 11:50 to 1:00

In attendance:

Michael Rodgers - President, Jim Powell – VP Legislative, Angela Bowman – VP Technical, Keith Lorah – VP Membership, Joseph Carbonel – Treasurer, Dan Perkins – Administrative Secretary, Joseph Nicolich – Administrative Secretary, Richard Lingo - Editor/Web Site Curator, Bruce Jenkins – Affiliate Liason

Agenda Items:

Technical Items:

Speaker for November: Colleen from Environmental Health Department to discuss new codes and regulations.

Calendar of Technical Discussions for 2007/2008 session?

Dec: DSA Representative

Jan: Glumac office LEED Platinum; Yearly social event

Fed: Grease Interceptor Sizing

March: Nor-Cal ASOPE Table Top

Seminars:

Siphonic Roof Drainage

IAPMO Code Changes

April: TBA

May: TBA

Possible other topics:

Fire pump sizing

NFPA 20

CSST-Gas Tight

Seismic-Mason

Sewage ejectors

NFPA 99 2002 vs 2005

Technical Topics for Annual Tech. Seminars/Table Top Event

March: Table top/2 seminars, Bill Kapenan-Tuesday March 11, 2nd Tues @ Radisson, will soon have flyers, announcements and affiliate letters.

Siphonic Roof Drainage

IAPMO Code Changes

[See Page-13 for Continuation](#)



V.P. Membership Message

Greetings all,

In an effort to raise the membership levels of our Chapter, I am proposing the following incentives for members that recruit new members. The Grand Prize for the member responsible for bringing the most new members to The Chapter will receive a gift certificate good for dinner (restaurant yet to be determined). Second and third place members shall be awarded an ASPE shirt. The Chapter Board will also consider any past members that have dropped from the roster that you bring back into the fold as new. I am asking the Board Members to exclude themselves from this contest as many of us feel it is our responsibility to talk to new prospects and past members as part of our duties. Look for the next email blast for meeting date and location!

Did you change your job? Did your office change locations?

When you change jobs or move, let us know your new contact information. It is important that you provide a current email address so you don't miss out on what's happening. You can go online to <http://aspe.org> and scroll to the bottom of the page to see the Update area or contact me.

Not an ASPE member yet?

To become a new ASPE member you can go online to <http://aspe.org> or contact me direct at klorah@glumac.com

Thank you,

Keith Lorah
VP Membership – Nor Cal Chapter of ASPE

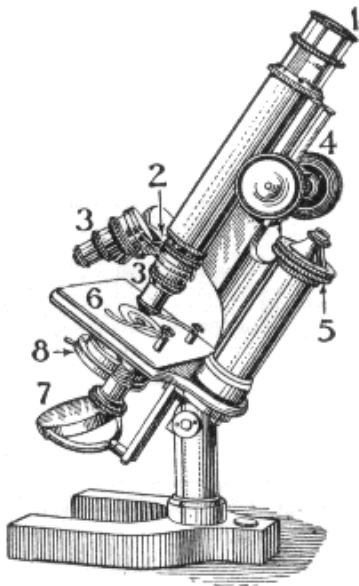

That new member may be right below you nose.



P/ F 916-928-6859 Cel 510-589-3564
Principals:
Ted Davids & John Bellamy
4720 Loch Lomond Dr.
Carmichael, CA 95608

Industrial/Commercial Specification Representatives Serving No. California & No. Nevada

- **Fiberglass suspension and framing products.**
- www.alliedsupport.com

FLEX Tubing Products

- **PVC, PUR ESTER/ETHER and LLDPE flexible tubing.**
- www.flextubing.com



ENFIELD[®]
ELECTROFUSION ACID WASTE SYSTEM

LABLINE[™]
MECHANICAL JOINT ACID WASTE SYSTEM

Duraplus[®]
ARB INDUSTRIAL SYSTEM

enpure[™]
HIGH PURITY PP SYSTEM

Duratec[™]
air-line

NEUTRATANK[®]
NEUTRALIZATION TANKS

Xirtec140
PP PROCESS PIPING SYSTEM

Encase[™]
PP Double Containment System

Guardian
Vinyl Double Containment Systems

- www.ipexinc.com



- **Magnetic drive, waste water, submersible and condensate pumps.**
- www.littlegiant.com

Plast-O-Matic
Valves, Inc.

- **Thermoplastic control valves, pressure & relief valves and manual and actuated ball valves.**
- www.plastomatic.com



- **Hot water temperature maintenance and pipe-line freeze protection.**
- www.thermon.com



- **Metal framing channel, fittings and clamps.**
- www.wesanco.com

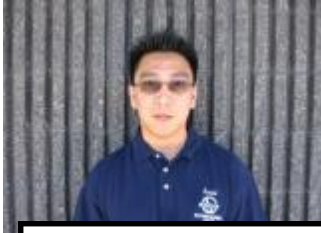

Treasurer's Report

Hi everyone!

This month we'll be meeting at The Old Spaghetti Factory, located at Hazel & Folsom Blvd. Rancho Cordova, CA

The cost for lunch will be \$15.00 per person and the cost for students with a VALID student ID or current class schedule will be \$10.00.

Congratulations to Judy Gregory of Sacramento Engineering Consultants for being our ***November Free Lunch*** winner!!

I would like to remind everyone that we are now accepting donations for our Annual Food Drive. Check and cash donations are acceptable as well. Make check payable to: Northern California Chapter of ASPE and we'll do the shopping for you!

Make sure to bring your donations at this months membership meeting, Tuesday the 13th of November. Thank you for your support.

If you're interested in buying a Northern California Chapter of ASPE shirt, please feel free to contact me for information. Again, the cost for one shirt is \$35.00.

For those of you who want to place an ad to the ASPE newsletter, there is still plenty of room. If you have any questions or concerns regarding placing an ad, please do not hesitate to call. The advertisement price list can be found in our website at <http://aspe-norcal.org>.

You can pay for your shirt and advertising using PayPal. Please send me an e-mail with your shirt and/or advertising order and I will send you an invoice with your total. You do not have to be a member of PayPal to use this feature and it costs you nothing to use.

Please feel free to contact me with any questions you might have regarding advertising in the Chapter Newsletter or anything else.

Thanks,

Joseph Carbonel

Treasurer-Nor Cal Chapter of ASPE

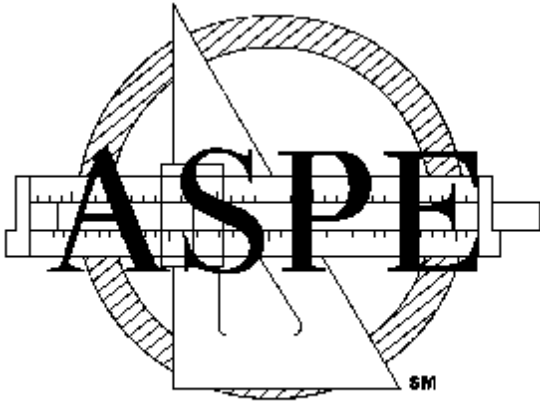

2006-2007 Chapter Officers:

President:

Michael Rodgers
Capital Engineering
11020 Sun Center Drive, Suite 100
Rancho Cordova, CA 95670
Mrodgers@capital-engineering.com

Vice-President Technical:

Angela Bowman
Capital Engineering
11020 Sun Center Drive, Suite 100
Rancho Cordova, CA 95670
Abowman@capital-engineering.com

Vice-President Legislative:

James Powell, CIPE
Ainsworth Associates
3741 Business Drive
Sacramento, CA 95820
Jpowell@aa-me.com

Vice-President Membership:

Keith Lorah
Glumac
910 Glenn Drive
Folsom, CA 95630
Klorah@glumac.com

Treasurer:

Joseph Carbonel
Capital Engineering
11020 Sun Center Drive, Suite 100
Rancho Cordova, CA 95670
Jcarbonel@capital-engineering.com

Marketing/ AV:

Dan Perkins
Daybreak Technologies, Inc.
3000 Alamo Drive, #204
Vacaville, CA 95687
Dan@daybreaktech.com

Product Show Coordinator:

Bill Kapanen
California Hydronics
2272 B Sierra Meadows Drive
Rocklin, CA 95677
Bkapanen@calhydro.com

Administrative Secretary:

Joseph Nicolich
Borm Engineers
131 L Street
Sacramento, CA 95814
Josephn@borm.com

Affiliate Liaison:

Bruce Jenkins
Elmco & Associates
bjenkins@elmcoassoc.com

Newsletter Editor/Webmaster:

Richard Lingo
Capital Engineering
11020 Sun Center Drive, Suite 100
Rancho Cordova, CA 95670
Rlingo@capital-engineering.com

Board Meeting Minutes Cont.

Speaker Evaluations.

Meeting Location

Stay downtown – last meeting poorly attended

Attendance of board members is required at general membership meeting if at all possible

Membership Items:

Ideas for membership programs?

Offer a giveaway to person who refers most new members

Send welcome card to new members

Email Blasts (Membership Meetings).

They are going out and seem to be working

Response to inquiry of membership status:

Calls are being made, some favorable response

Treasurer's Report:

Absent due to personal reasons

Open Discussion:

Chapter Web Site: Revision to be made

Next notice of meeting

Calendar of events

Revise table top dates

Company profiles to be removed

AB715: ultra low flow 1.28 gpf water closets or @ 0.5 gpf urinals

UCD Plumbing Courses – status report from Richard Lingo, book purchase for the UCD Courses.

Report from Richard Lingo Going says classes are going well, 16 in attendance

Michael Rodgers to schedule visit to class.

Product Show (reserving the date, the place, etc...)

Tuesday, March 11, 2008 Radisson Hotel

Bill Kapanen to ratify contract

Food Drive for November:

Announce in Newsletter, donated items should be brought to Membership meeting.

Nor-Cal ASPE will donate monetary value as well.

Run To Feed The Hungry.

Application on website

Are the speaker evaluations, etc... being sent to the Region 4 Director?

Joe to follow up

Where are quarterly regional reports? No info from society.

Newsletter articles are due NO LATER THAN – Wednesday, October 31st.

Next Board Meeting: Tuesday November 20th, 2007

Evening meeting needed for chapter budget discussion.